Maintenance Manual

for

Manually & Motor Operated Counter Fire, Smoke & Draft Control Doors



1340 Midway Blvd
Mississauga, Ontario
Tel: 905-670-1200
Fax: 905-670-8830

Job No. _____

Job Name _____

This troubleshooting manual has been specifically written to provide a concise source of information to all customers of Service Door Industries. This information will provide solutions to the most common problems and establish a systematic sequence required to repair a rolling door.

PURPOSE

When a problem is encountered that is not covered in this manual, please consult Service Door Industries.

CUSTOMER SERVICE

Service Door Ind. — (905) 670-1200

When requesting information or ordering replacement parts, you must provide the following information.

ITEM

1. Job Number
2. Door Hand
3. Operator Voltage & Phase
4. Operator Model Number
5. Job Location

NOTE:

For maintenance or repair of this door, please consult your local authorized Distributor.

**PARTS LIST:
FACE MOUNTED,
PUSH-UP OPERATED
COUNTER FIRE DOOR**

NO.	ITEM
1	Curtain
2	Guides
3	Hood
4	Barrel
5	Stop
6	Tension Bracket
7	Drive Bracket
8	Tension Side Tension Wheel
9	Scape Wheel
10	Drive Side Tension Wheel
11	Spring

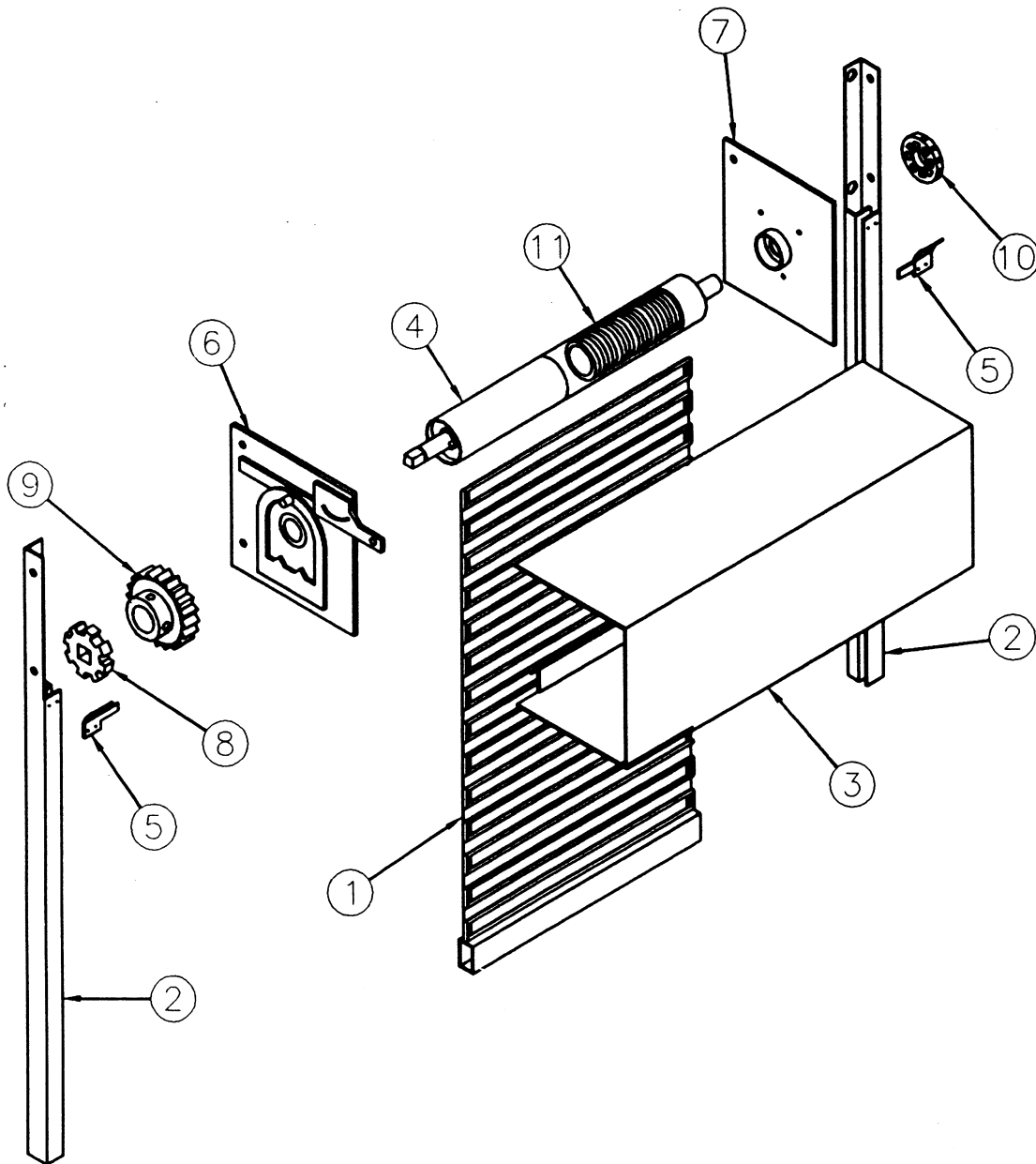

NO.	ITEM
1	Curtain
2	Guides
3	Hood
4	Barrel
5	Stop
6	Tension Bracket
7	Drive Bracket
8	Tension Side Tension Wheel
9	Scape Wheel
10	Drive Side Tension Wheel
11	Fascia
12	Spring

**PARTS LIST:
JAMB MOUNTED,
PUSH-UP OPERATED
COUNTER FIRE DOOR**

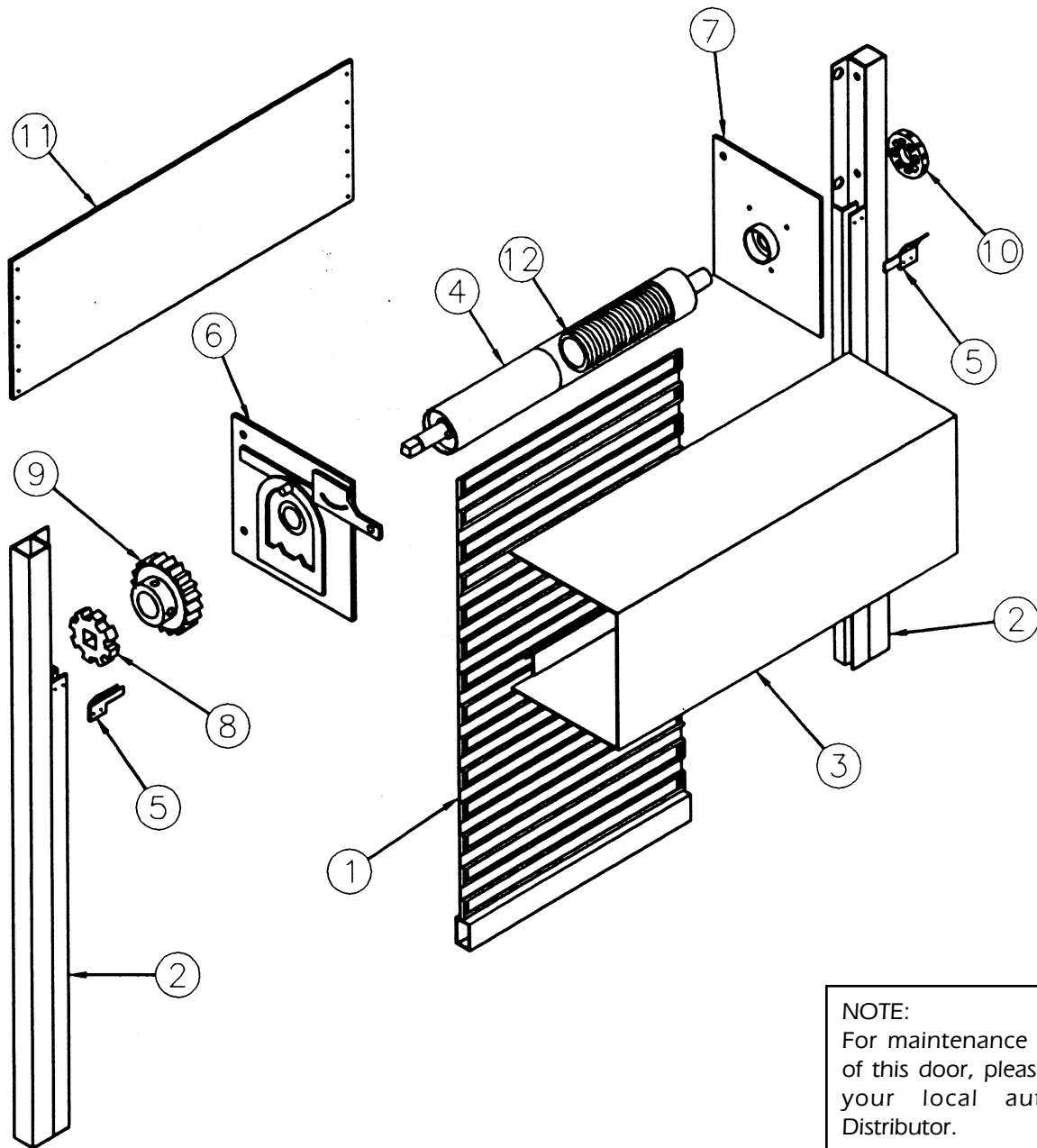

NOTE:
For maintenance or repair
of this door, please consult
your local authorized
Distributor.

**PARTS LIST:
FACE MOUNTED,
CRANK OPERATED
COUNTER FIRE DOOR**

NO.	ITEM
1	Curtain
2	Guides
3	Hood
4	Barrel
5	Stop
6	Tension Bracket
7	Drive Bracket

NO.	ITEM
8	Tension Side Tension Wheel
9	Scape Wheel
10	Drive Side Tension Wheel
11	Winding Shaft
12	Crank Box
13	Spring

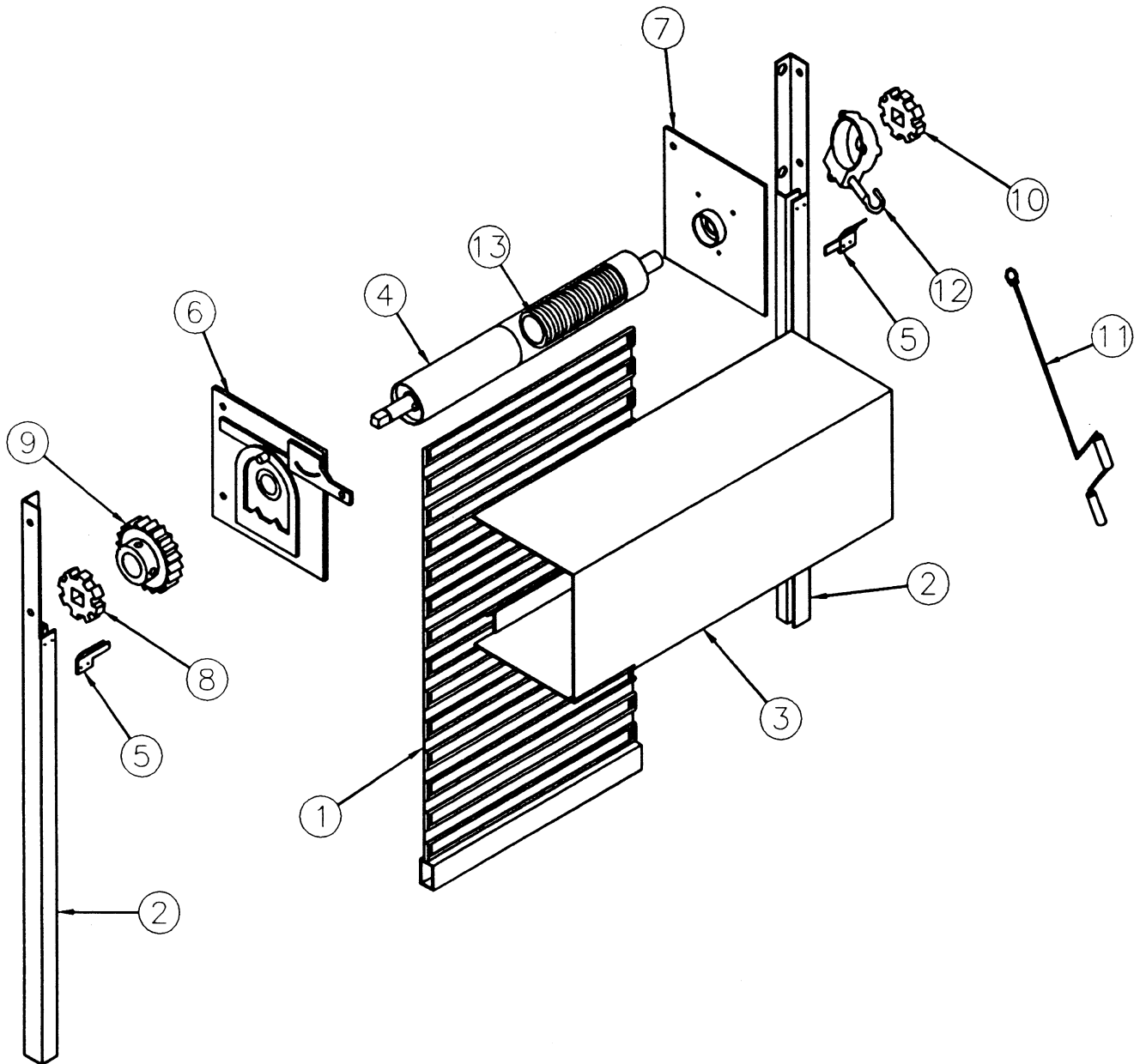

NO.	ITEM
1	Curtain
2	Guides
3	Hood
4	Barrel
5	Stop
6	Tension Bracket
7	Drive Bracket

NO.	ITEM
8	Tension Side Tension Wheel
9	Scape Wheel
10	Drive Side Tension Wheel
11	Winding Shaft
12	Fascia
13	Crank Box
14	Spring

**PARTS LIST:
JAMB MOUNTED,
CRANK OPERATED
COUNTER FIRE DOOR**

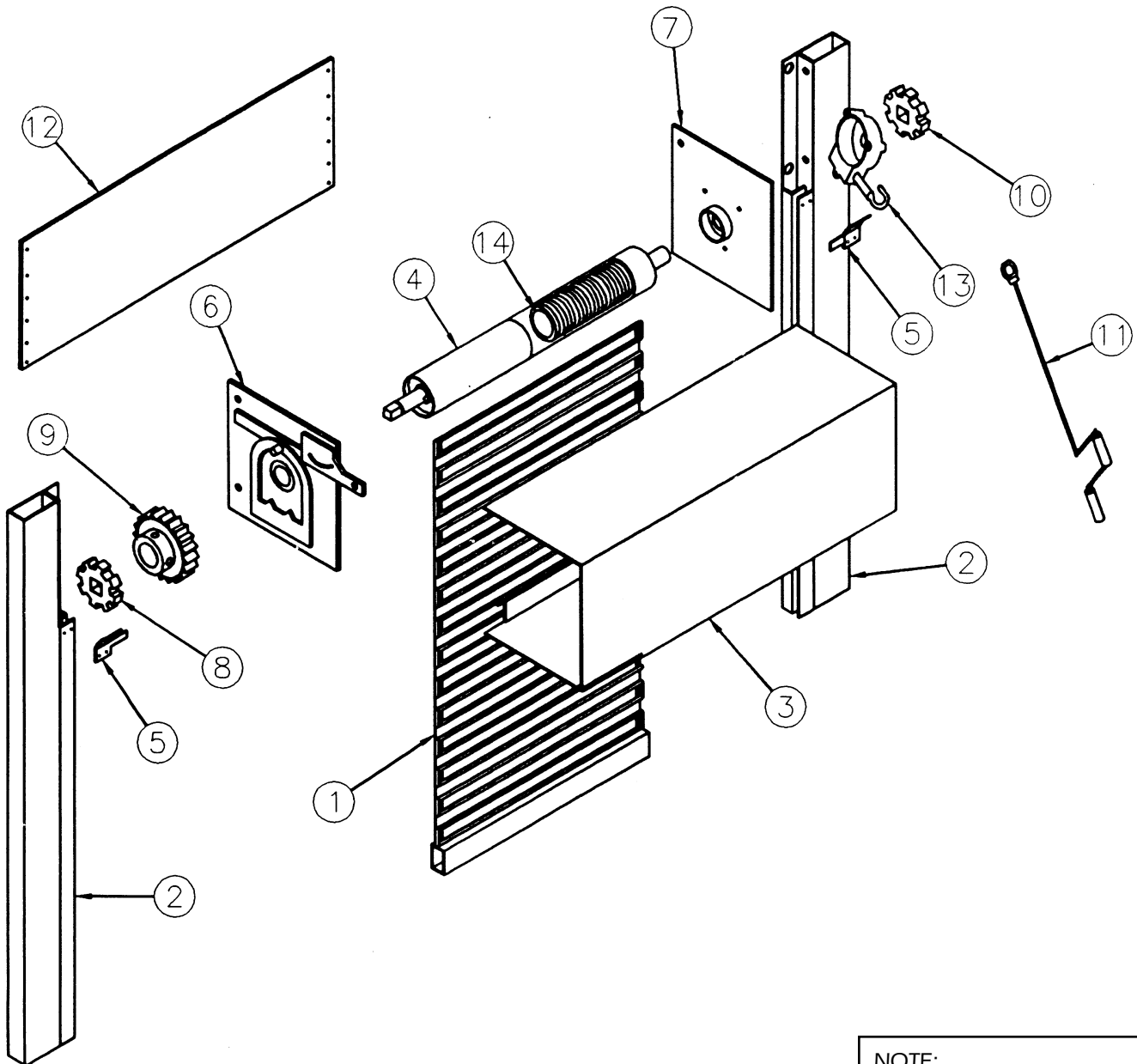

NOTE:
For maintenance or repair
of this door, please consult
your local authorized
Distributor.

**PARTS LIST:
FACE MOUNTED,
MOTOR OPERATED
COUNTER FIRE
DOOR**

NO.	ITEM
1	Curtain
2	Guides
3	Hood
4	Barrel
5	Stop
6	Drive Bracket
7	Tension Bracket
8	Tension Wheel
9	Motor Operator
10	Limit Switch
11	Spring

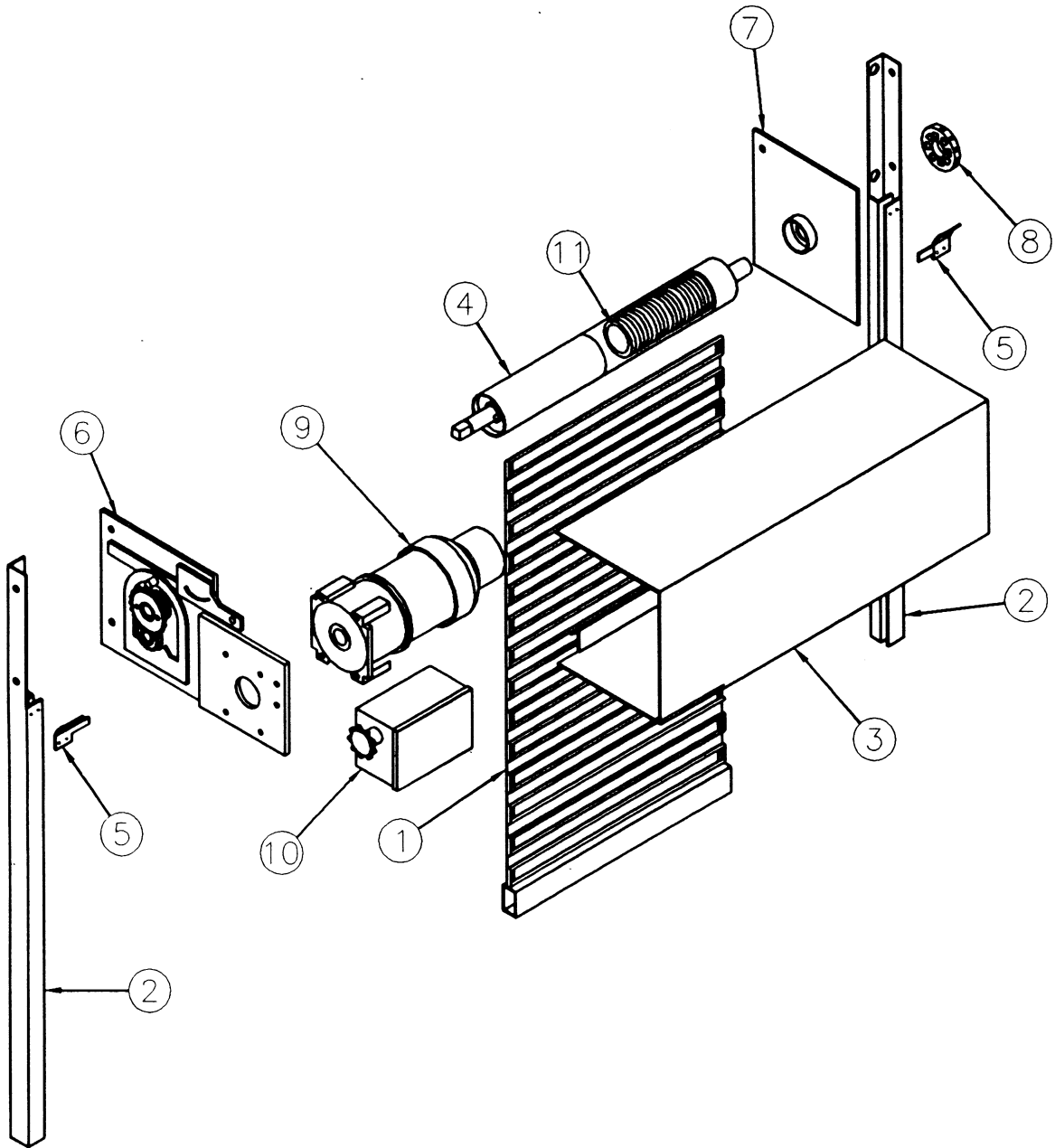

NO.	ITEM
1	Curtain
2	Guides
3	Hood
4	Barrel
5	Stop
6	Drive Bracket
7	Tension Bracket
8	Tension Wheel
9	Limit Switch
10	Motor Operator
11	Spring

**PARTS LIST:
FACE MOUNTED,
MOTOR OPERATED
COUNTER FIRE
DOOR W/ TOP
MOUNTER MOTOR**

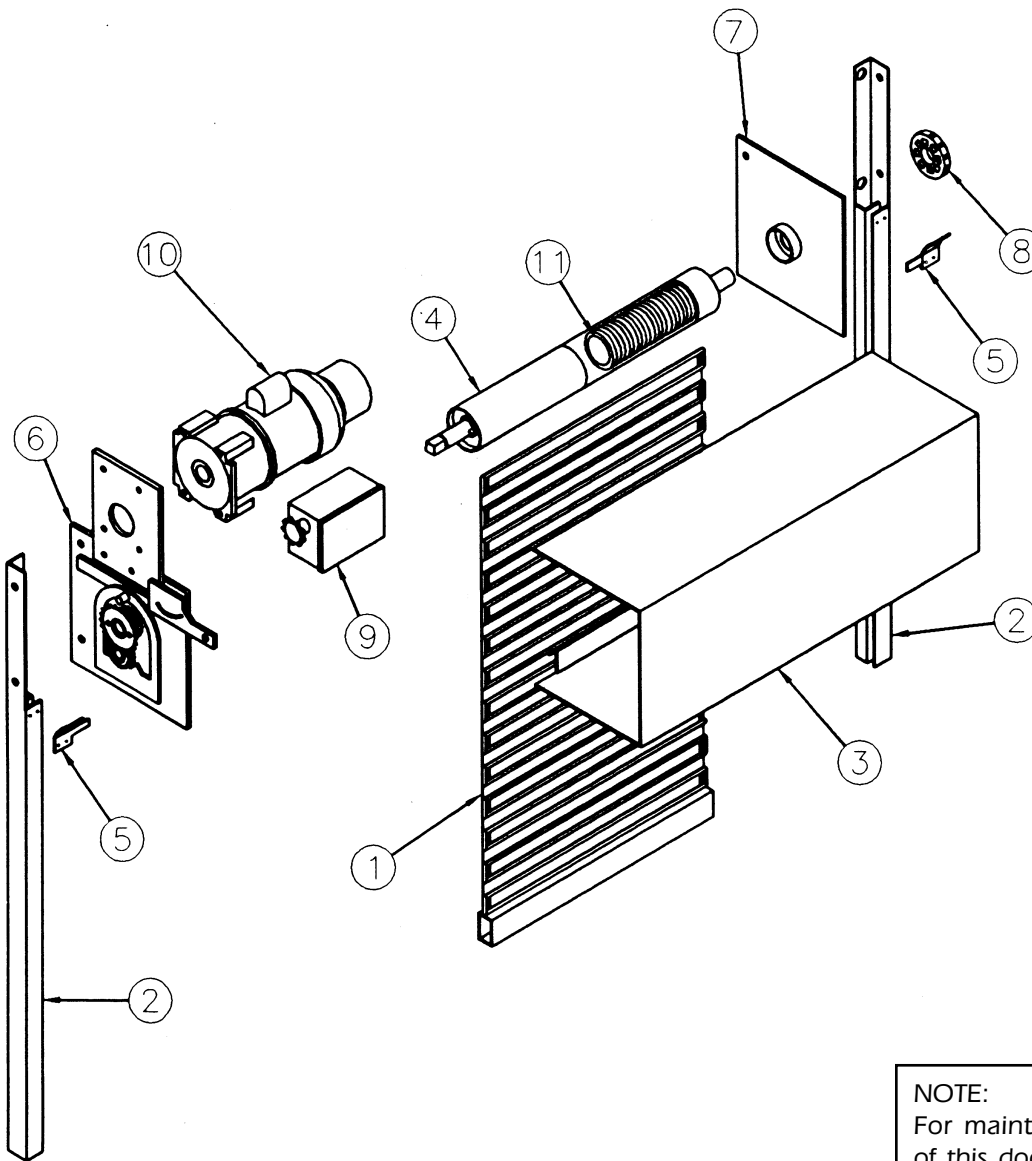

NOTE:
For maintenance or repair
of this door, please consult
your local authorized
Distributor.

**PARTS LIST:
PUSH-UP OPERATED
COUNTER FIRE
DOOR W/ INTEGRAL
FRAME**

NO.	ITEM
1	Curtain
2	Guides
3	Hood
4	Barrel
5	Stop
6	Tension Bracket
7	Drive Bracket
8	Tension Side Tension Wheel
9	Inside Frame

NO.	ITEM
10	Tension Side End Cover
11	Drive Side End Cover
12	Fascia
13	Countertop
14	Outside Frame
15	Drive Side Tension Wheel
16	Spring
17	Scape Wheel

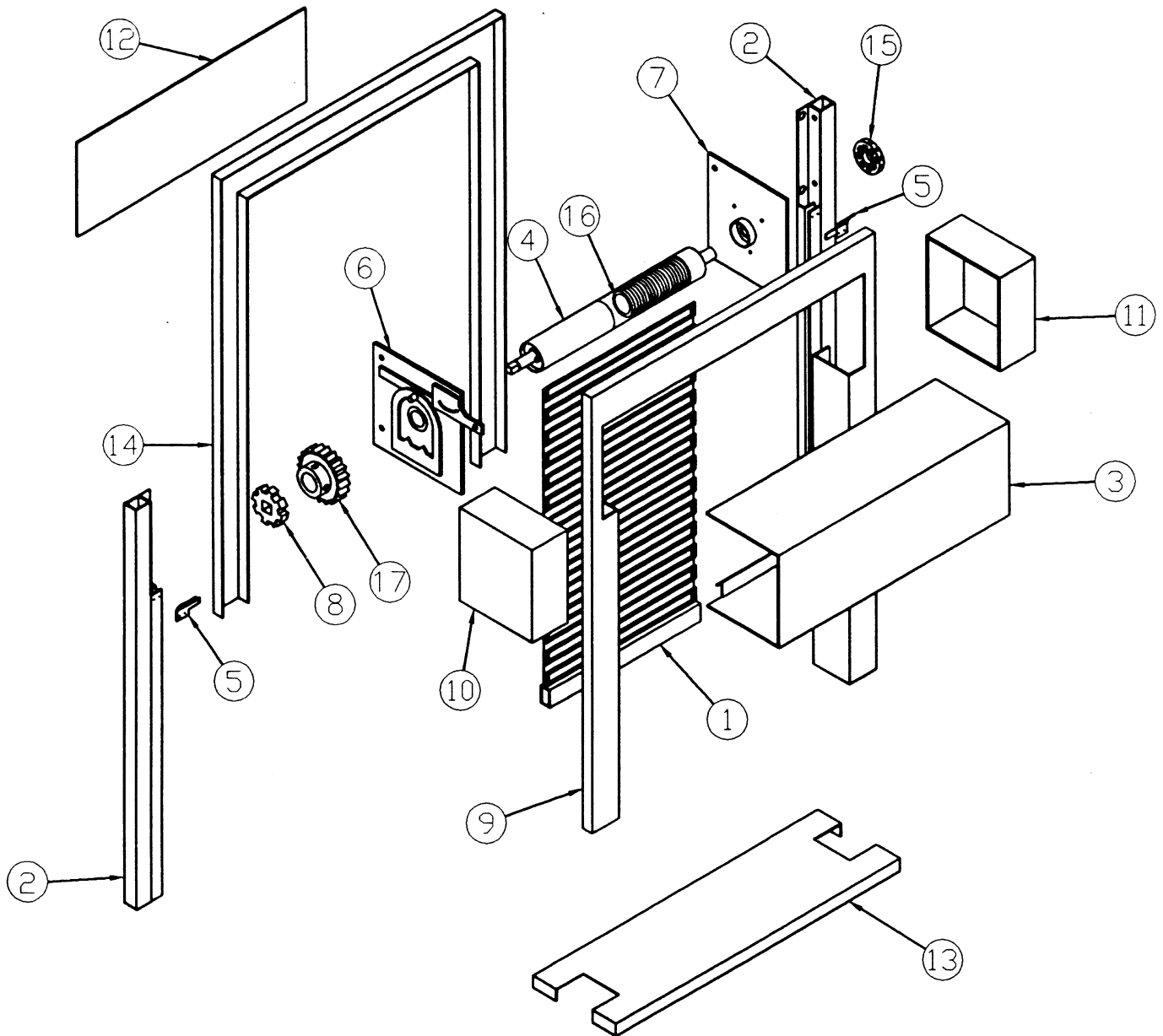

NO.	ITEM
1	Curtain
2	Guides
3	Hood
4	Barrel
5	Stop
6	Tension Bracket
7	Drive Bracket
8	Tension Side Tension Wheel
9	Scape Wheel
10	Drive Side Tension Wheel
11	Smoke Gaskets
12	Spring

**PARTS LIST:
FACE MOUNTED,
PUSH-UP OPERATED
COUNTER SMOKE &
DRAFT CONTROL
DOOR**

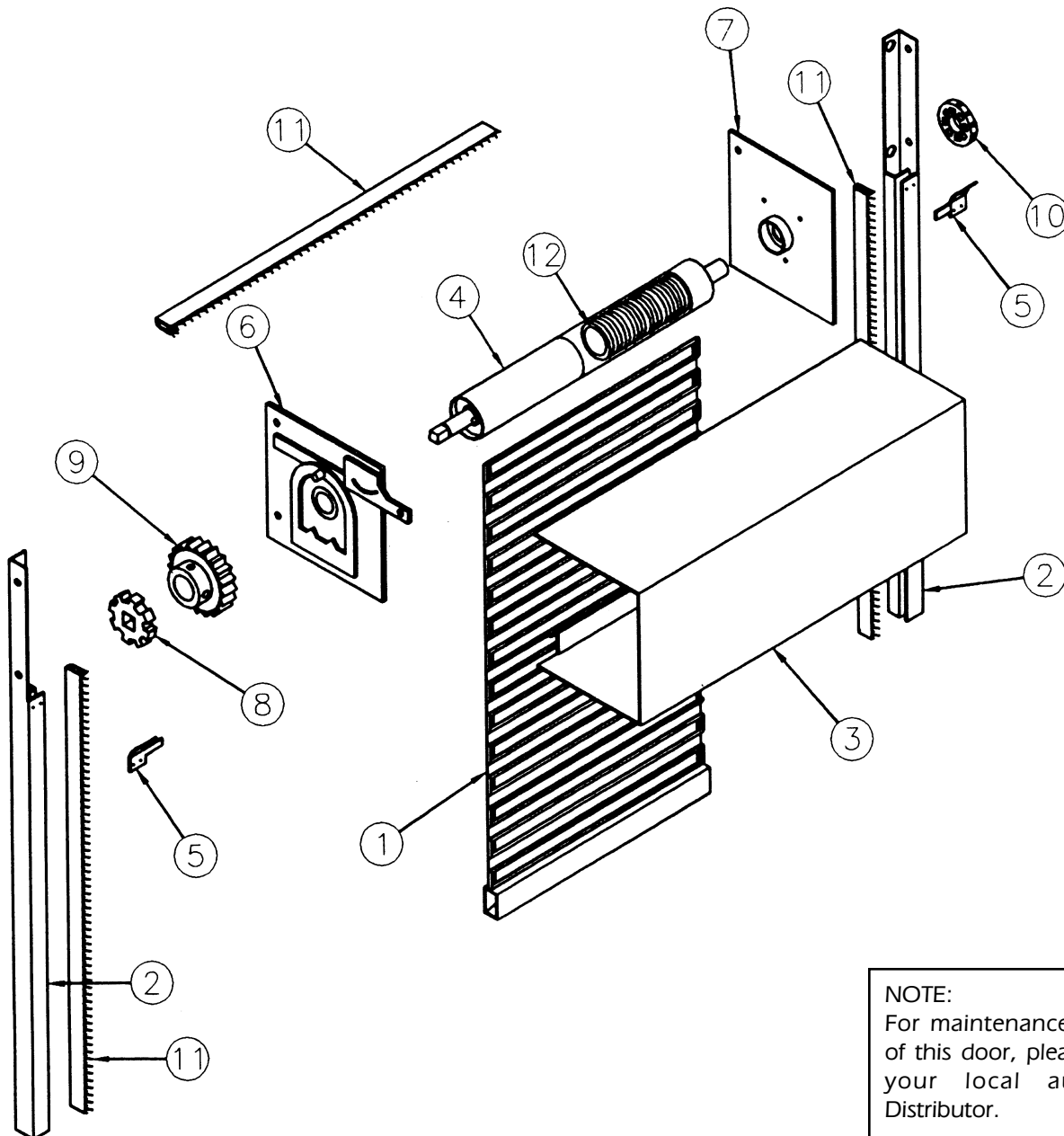

NOTE:

For maintenance or repair of this door, please consult your local authorized Distributor.

**PARTS LIST:
JAMB MOUNTED,
PUSH-UP OPERATED
COUNTER SMOKE &
DRAFT CONTROL
DOOR**

NO.	ITEM
1	Curtain
2	Guides
3	Hood
4	Barrel
5	Stop
6	Tension Bracket
7	Drive Bracket

NO.	ITEM
8	Tension Side Tension Wheel
9	Scape Wheel
10	Drive Side Tension Wheel
11	Fascia
12	Smoke Gaskets
13	Spring

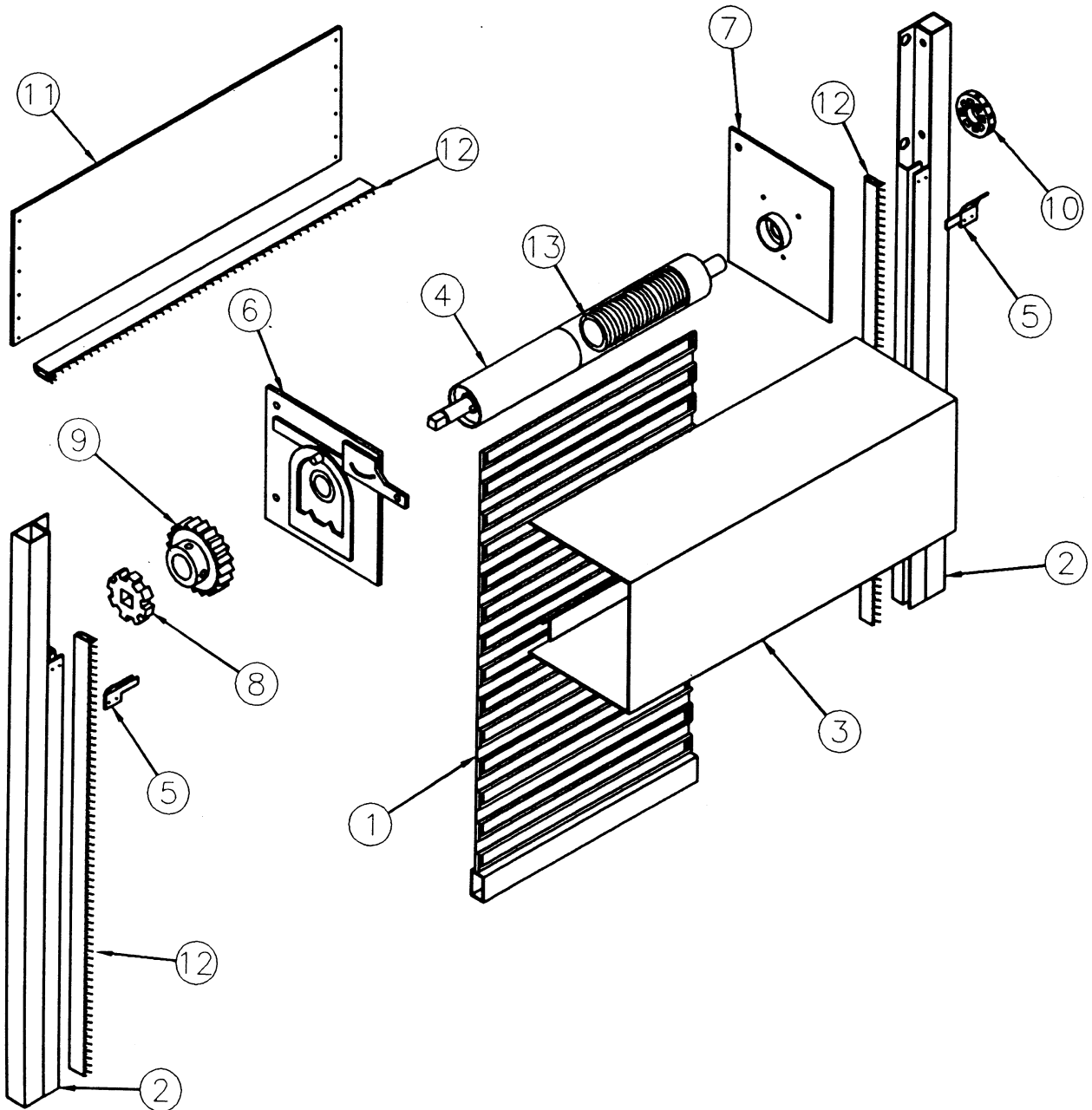

NO.	ITEM
1	Curtain
2	Guides
3	Hood
4	Barrel
5	Stop
6	Tension Bracket
7	Drive Bracket

NO.	ITEM
8	Tension Side Tension Wheel
9	Scape Wheel
10	Drive Side Tension Wheel
11	Winding Shaft
12	Smoke Gaskets
13	Crank Box
14	Spring

**PARTS LIST:
FACE MOUNTED,
CRANK OPERATED
COUNTER SMOKE &
DRAFT CONTROL
DOOR**

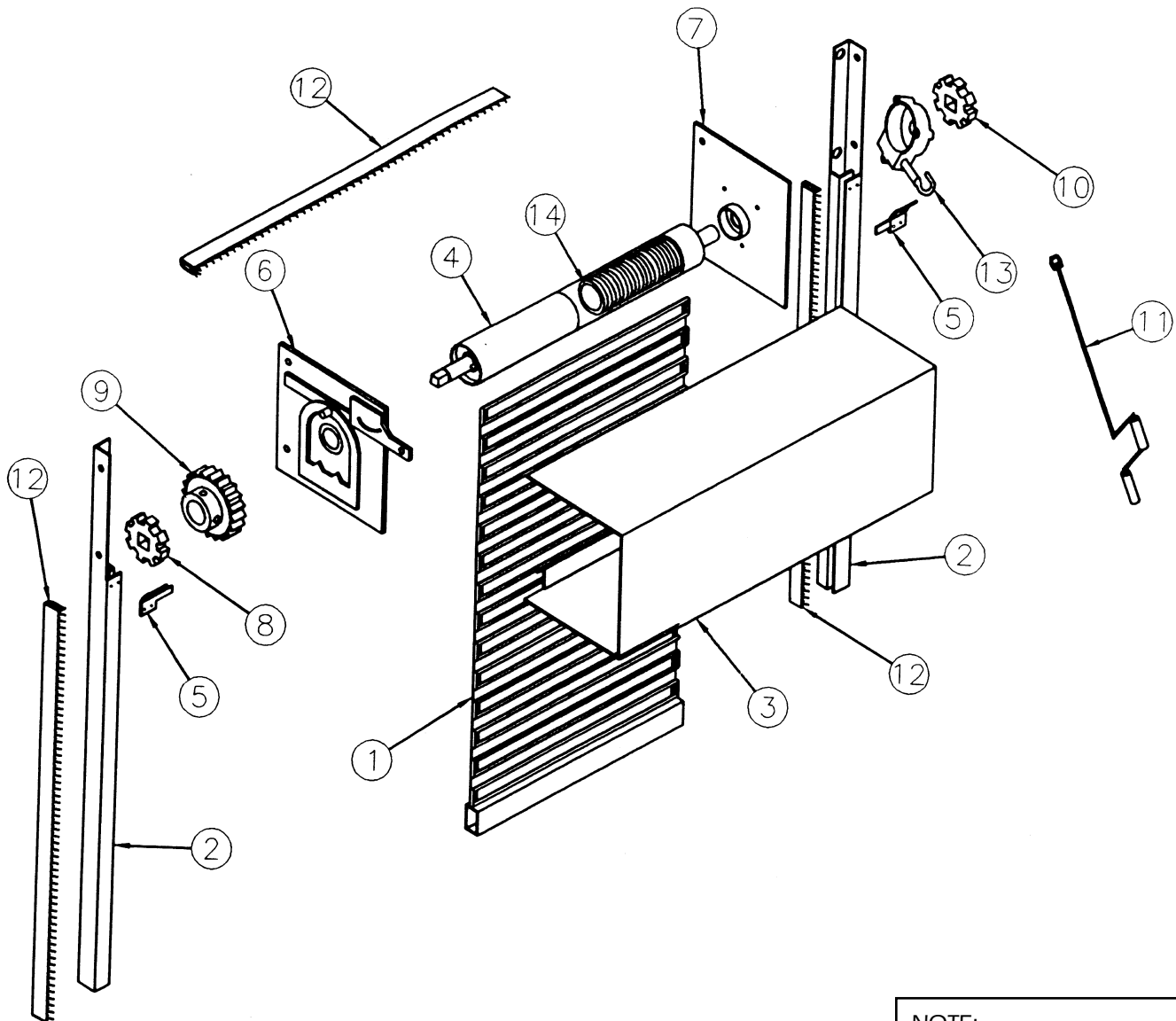

NOTE:
For maintenance or repair
of this door, please consult
your local authorized
Distributor.

NO.	ITEM
1	Curtain
2	Guides
3	Hood
4	Barrel
5	Stop
6	Drive Bracket
7	Tension Bracket
8	Tension Wheel
9	Motor Operator
10	Limit Switch
11	Smoke Gaskets
12	Spring

**PARTS LIST:
FACE MOUNTED,
MOTOR OPERATED
COUNTER SMOKE &
DRAFT CONTROL
DOOR**

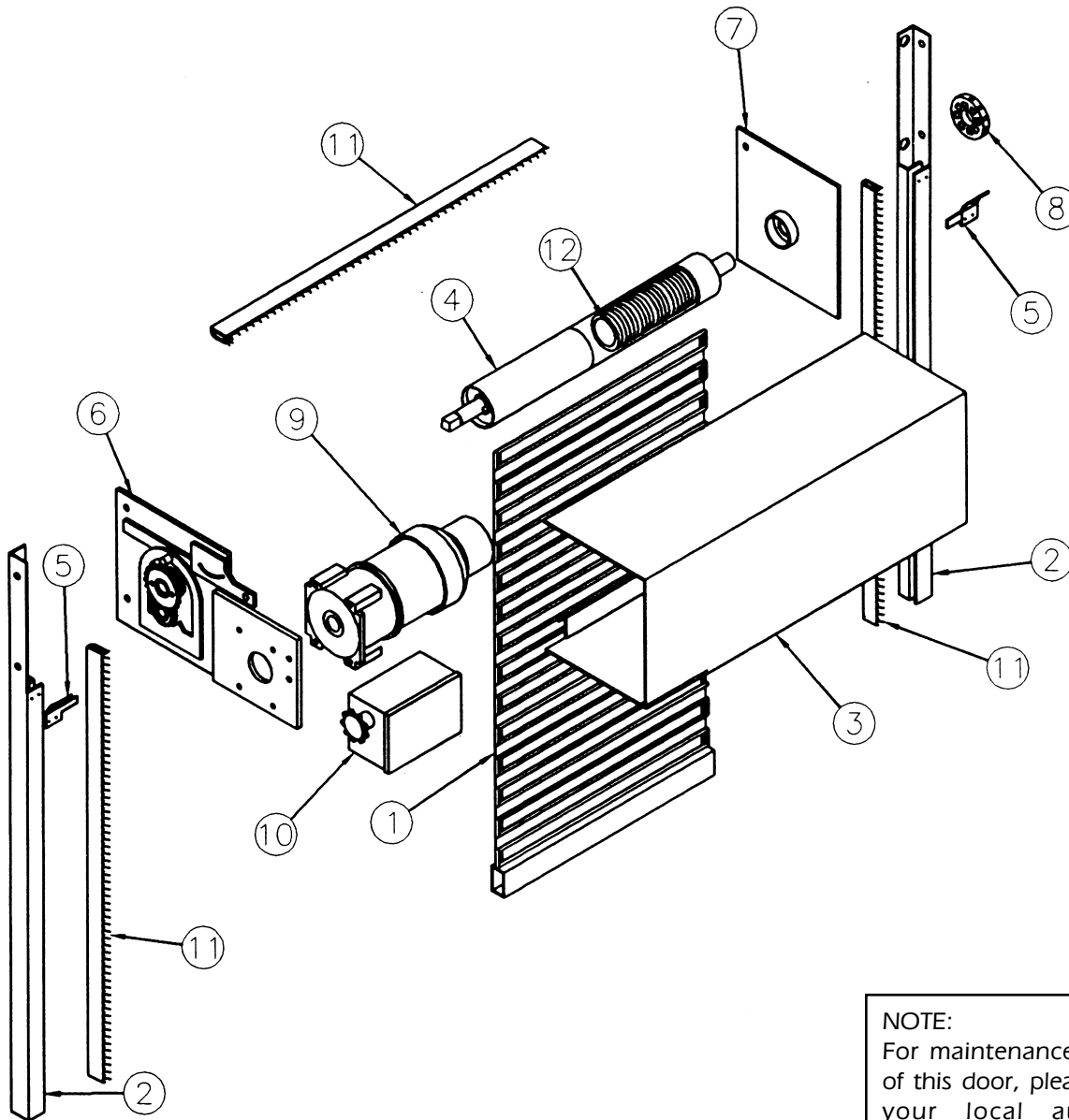

NOTE:
For maintenance or repair
of this door, please consult
your local authorized
Distributor.

**PARTS LIST:
FACE MOUNTED,
MOTOR OPERATED
COUNTER SMOKE &
DRAFT CONTROL
DOOR W/ TOP
MOUNTER MOTOR**

NO.	ITEM
1	Curtain
2	Guides
3	Hood
4	Barrel
5	Stop
6	Drive Bracket
7	Tension Bracket
8	Tension Wheel
9	Limit Switch
10	Motor Operator
11	Smoke Gaskets
12	Spring

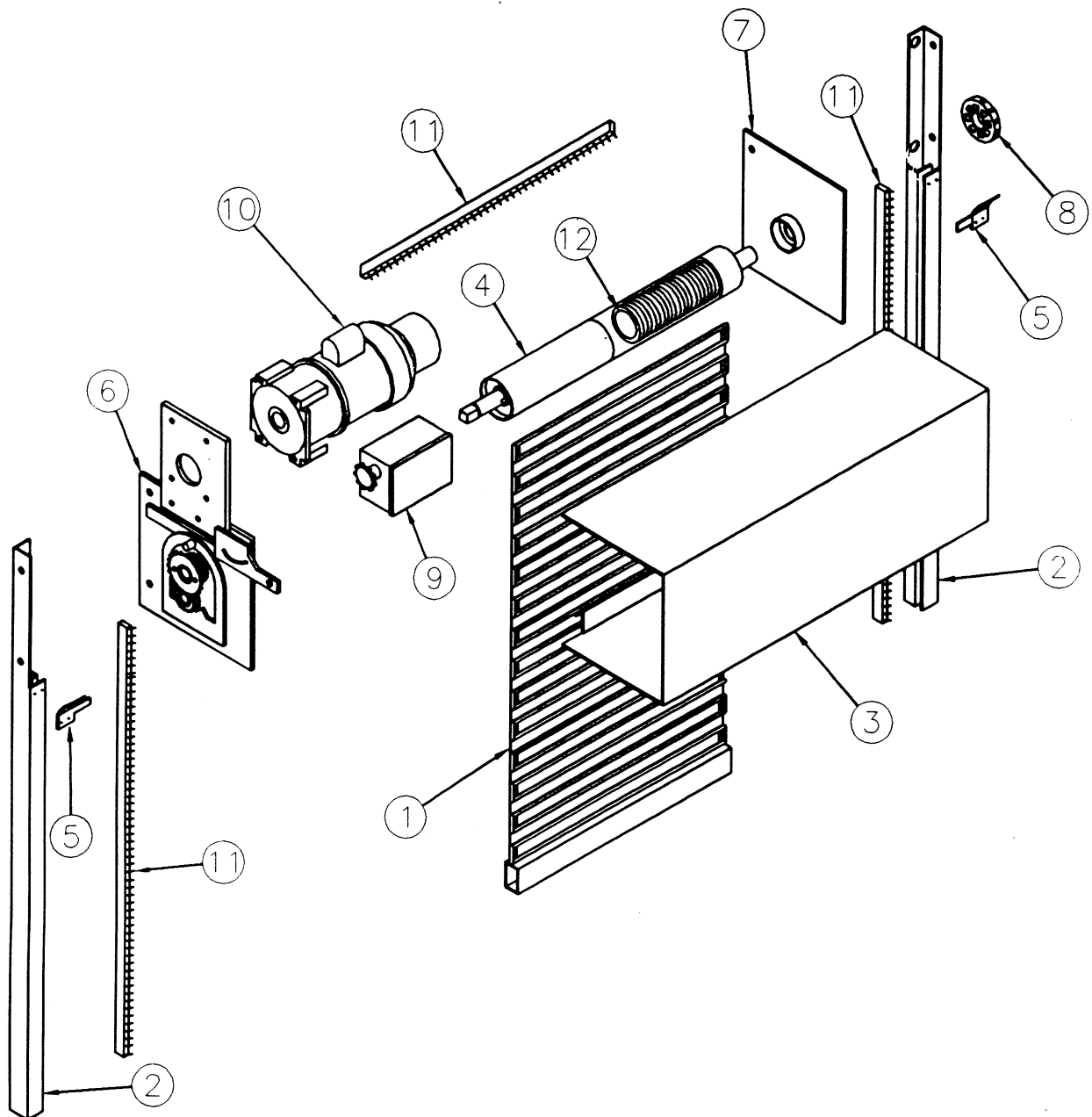

NO.	ITEM
1	Curtain
2	Guides
3	Hood
4	Barrel
5	Stop
6	Tension Bracket
7	Drive Bracket
8	Tension Side Tension Wheel
9	Inside Frame

NO.	ITEM
10	Tension Side End Cover
11	Drive Side End Cover
12	Fascia
13	Countertop
14	Outside Frame
15	Drive Side Tension Wheel
16	Smoke Gasket
17	Scape Wheel
18	Spring

**PARTS LIST:
PUSH-UP OPERATED
COUNTER SMOKE &
DRAFT CONTROL
DOOR W/ INTEGRAL
TRIM**

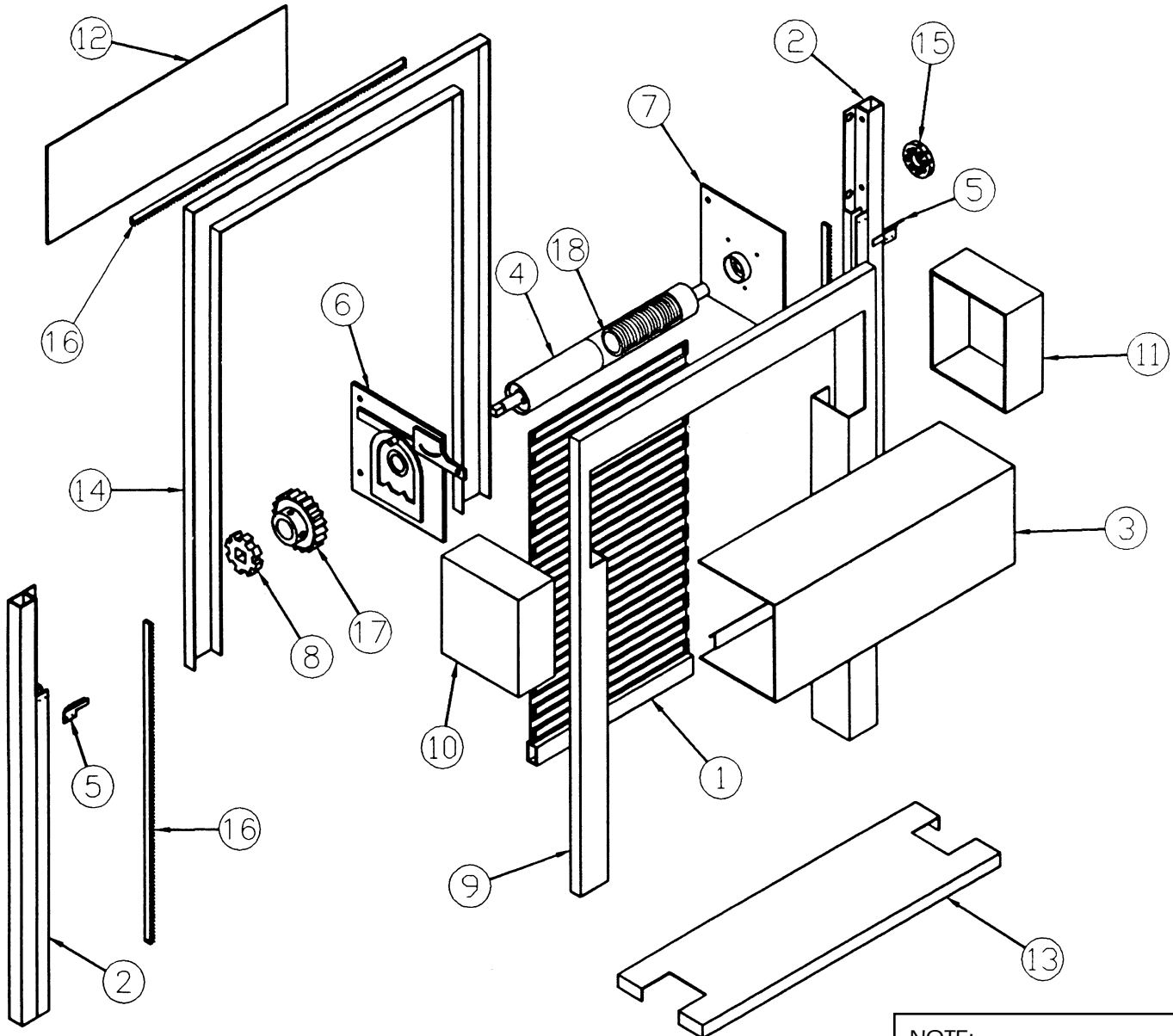

NOTE:
For maintenance or repair
of this door, please consult
your local authorized
Distributor.

DOOR INSTALLATION

- A.* Many problems encountered with rolling counter fire doors are a result of improper installation of the door. Each door is provided with a set of installation instructions that must be followed to insure proper operation. Installation problems can remain undetected on doors that are seldom operated, therefore it is important to consider incorrect installation as a common cause of problems.
- B.* A door must be inspected prior to installation to insure that none of the components have been damaged in shipment. Damaged components should not be used to install a door.
- C.* The guides of the door must be plumb and mounted the correct distance apart along their entire length. Mounting hardware must not project into the guide because the curtain must be free to move in the guide. The tops of guides must be level to insure that the barrel of the door is level. The use of a Hydro-Level is an accurate method of leveling the guides.
- D.* The barrel of the door must be free to turn when supported by the brackets. If hoops are required, they must be installed on the barrel before the curtain and brackets are installed on the barrel. The curtain is attached to the barrel with machine screws that pass through slots in the top slat.
- E.* The curtain of the door must pass freely through the guides without binding. The guides must be plumb and mounted to the correct guide opening dimension. The guide groove opening must be adjusted to the dimension shown in the installation instructions.
- F.* The torsion spring must be tensioned to the number of initial turns shown in the installation instructions. On large motor operated doors, it may not be possible to raise the door by hand if the initial tension is not applied. When this occurs, the weight of the door must be lifted while the hand operator is used to coil the curtain on the barrel.
- G.* The door operator must be free to turn and securely mounted to the bracket. Bracket plates must be perpendicular to the barrel to insure that chains, sprockets, and gears engage properly.
- H.* All door components are labeled, stamped, or tagged with corresponding Service Door Industries Mark. Parts must not be interchanged for different doors.

TROUBLESHOOTING GUIDE

PROBLEM	CAUSE	CORRECTION
A. Door starts down then binds.	1. Curtain binds in guides.	1. Increase guide groove opening. Curtain must be loose in guides.
	2. Screws connecting curtain to barrel too long and interfering with torsion spring.	2. Replace screws with shorter length. They must not protrude past barrel wall.
	3. Incorrect barrel for opening.	3. Check door mark. Locate correct barrel.
	4. Internal interference inside barrel. Dent in wall of barrel.	4. Consult Distributor.
B. Tension wheel turns freely.	1. Spring broken.	1. Consult Distributor.
	2. Broken shaft tie.	2. Consult Distributor.
	3. Broken barrel tie.	3. Consult Distributor.
C. Tension shaft slipped into barrel.	1. Drive pin failure - shipping damage	1. Consult Distributor.
	2. Bearing failure - shipping damage.	2. Consult Distributor.
D. Door loses tension.	1. Door damaged causing increased drag.	1. Consult Distributor.
E. Drive shaft crooked.	1. Broken weld or shipping damage.	1. Consult Distributor for determination if field repair is possible.

NOTE:
For maintenance or repair of this door, please consult your local authorized Distributor.

CURTAIN

TROUBLESHOOTING GUIDE		
PROBLEM	CAUSE	CORRECTION
A. Curtain rolls up unevenly.	1. Top slat not in line. 2. Barrel not level.	1. Loosen top screws and straighten curtain. 2. Use Hydro-level to level barrel.
B. Door curtain separates.	1. Freight damage.	1. Replace curtain.
C. Curtain separates from barrel.	1. Machine screws pulled through top slat. 2. Interlocks not installed on motor operated door.	1. Install washer under head of truss head screws. 2. Install interlocks to prevent motor operation when door is locked.
D. Finish problems.	1. Stainless steel door corrodes due to environmental conditions.	1. Clean door periodically with stainless steel wool and rinse with clean water.
E. Curtain appears to sag at center.	1. Center of curtain is against barrel and edge of curtain is pulled toward lintel as it enters guides. 2. Barrel deflection of wide doors. Should not exceed .03 inches per foot of opening width.	1. Curvature of curtain makes it appear to be sagging while it is actually level. Check with carpenter's level. 2. Consult Distributor.

TROUBLESHOOTING GUIDE

PROBLEM	CAUSE	CORRECTION
A. Safety Edge not working.	1. Open circuit in bottom bar. Confirm this by disconnecting plug at bottom bar and inserting continuity checker. If pressing up on safety edge does not close circuit, problem is open circuit in bottom bar.	1. Defective switch or connection at switch to plug. Check to make sure all wires are securely fastened. Replace switch if necessary.
	2. Open circuit in coil cord or cord reel. Confirm this by inserting volt-meter into plug. Reading should be 24V AC.	2. Replace coil cord or cord reel.
	3. Door located in extremely wet or flood environment.	3. Eliminate water. Replace safety edge or safety edge switch.
B. Locks inoperative.	1. Cam of cylinder not in correct position.	1. Reposition cylinder and firmly secure with small cylinder screw located below cylinder.
	2. Damage to internal components.	2. Remove bottom bar from guide. Replace lock mechanism.
C. Electrical interlocks inoperative.	1. Lock bolt does not line up with switch on guide.	1. Adjust switch location where it is mounted on guides.
	2. Interlock does not prevent motor from operating.	2. Defective switch, check electrical connection and replace if necessary.

NOTE:

For maintenance or repair of this door, please consult your local authorized Distributor.

BRACKET

TROUBLESHOOTING GUIDE		
PROBLEM	CAUSE	CORRECTION
A. Brackets not perpendicular to barrel.	1. Wall angle flange not square.	1. Brace bracket into position.
B. Drive chain tension.	1. Sprocket position out of adjustment.	1. Tighten chain by sliding operator or remove link from chain.
C. Binding in bevel gear box.	1. Lack of lubrication.	1. Lubricate gear box.

GUIDE

TROUBLESHOOTING GUIDE		
PROBLEM	CAUSE	CORRECTION
A. Curtain binds in guide groove.	1. Incorrect guide groove opening. 2. Incorrect tip to tip dimension of guides.	1. Refer to installation instructions and adjust guide groove opening. 2. Refer to installation instructions for tip to tip dimension and adjust guide spacing.

HOOD

TROUBLESHOOTING GUIDE		
PROBLEM	CAUSE	CORRECTION
A. Incorrect dimensions, material, or end covers.	1. Ordering processing problem.	1. Get all dimensions of material supplied and consult factory.

TROUBLESHOOTING GUIDE

PROBLEM	CAUSE	CORRECTION
A. Emergency operation is difficult to operate door.	1. Door may be jammed or obstructed.	1. Remove Obstruction.
	2. Incorrect tension in spring.	2. Make sure that spring has correct tension.
	3. Door may be locked.	3. Check to see if lock is disengaged.
	4. Problem in gear box housing.	4. Consult Distributor.
B. Motor fails to run or control circuit fails to energize.	1. Fuses blown or circuit breaker "tripped".	1. Check fuse or circuit breaker box.
	2. Operators are protected from running in overload condition by thermal overload devices of the automatic reset type.	2. Consult Distributor.
	3. If contacts for motor controller energize but motor still fails to operate.	3. Consult Distributor.
	4. Pushbuttons energize on only one side of the control contacts.	4. Check all electrical connections for broken or loose wires, etc. Check electrical connections for any optional equipment: Card Key, Cylinder Key Switch, Photo Cell, Reversing Bottom Bar or Special Interlocks.
C. Movement of the door is in agreement with pushbutton station, but the limit switch does not stop the door.	1. Electrical connections are switched.	1. Check electrical connections and jumper wire lead between the micro switches. Consult Distributor.
D. Limit Switch does not hold its setting.	1. Sprocket shaft end play too large.	1. End play should not exceed 1/32".
	2. Drive chain loose.	2. Check drive chain.
	3. Limit switch detent plate loose.	3. The plate must engage both traveling cams.

NOTE:
For maintenance or repair of this door, please consult your local authorized Distributor.

**MOTOR OPERATOR
(continued)**

TROUBLESHOOTING GUIDE		
PROBLEM	CAUSE	CORRECTION
E. Electrical Control Circuit energizes but the motor does not run or motor overloads trip.	1. Incorrect wiring.	1. Consult Distributor.
F. Low voltage to motor.	1. Incorrect electrical power to motor.	1. Check voltage against the correct voltage stamped on the motor. If the voltage is 10% below the rating, there is not sufficient voltage to run the motor.
G. Motor is burned out.	1. Incorrect wiring.	1. Consult Distributor.

NO.	ITEM
1	Motor
2	Limit Switch
3	Drive Sprocket
4	Limit Switch Sprocket

**PARTS LIST:
MODEL 11
OPERATOR**

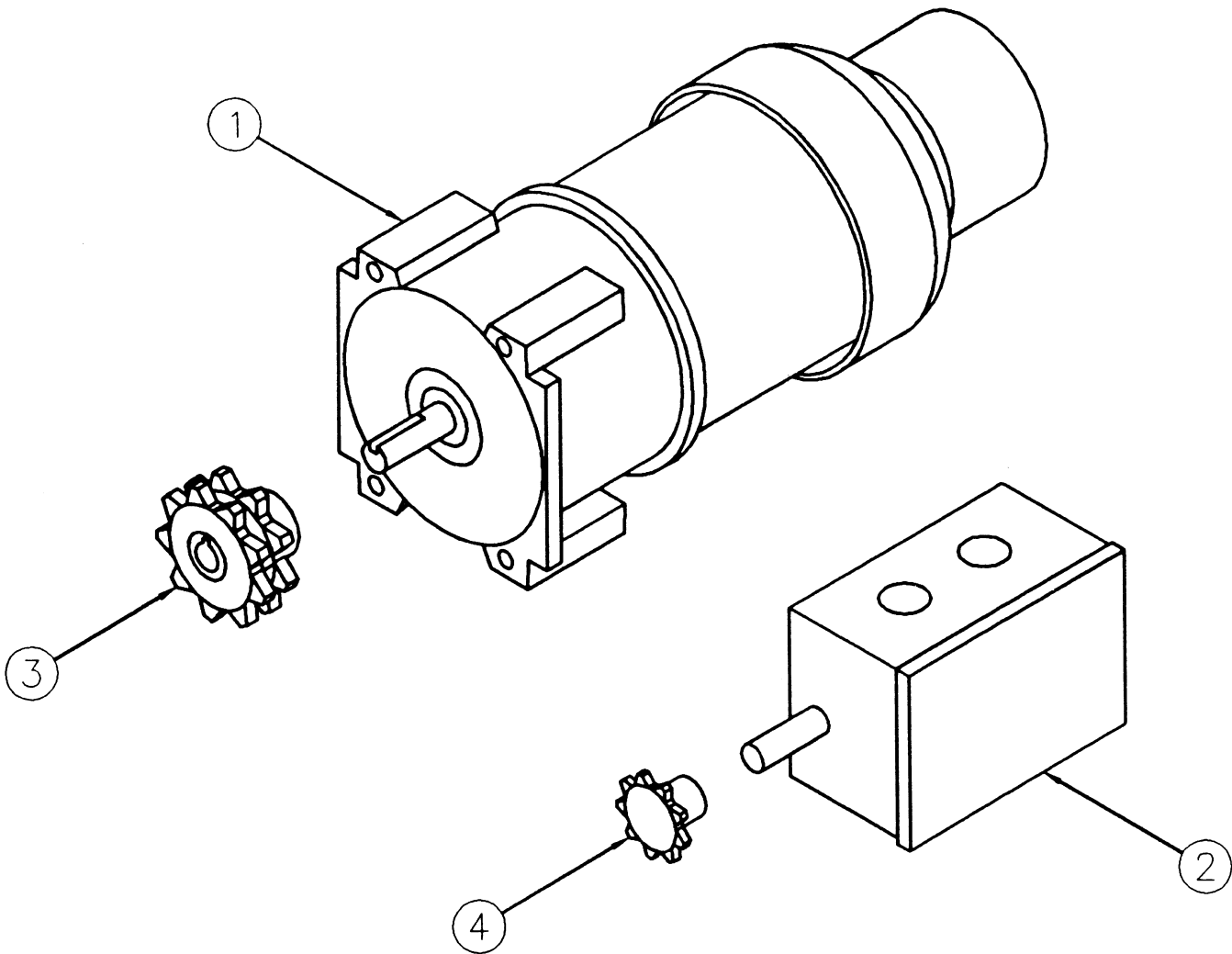

NOTE:
For maintenance or repair
of this door, please consult
your local authorized
Distributor.

**PARTS LIST:
MODEL GJ MOTOR**

NO.	ITEM
1	Reducer
2	Motor
3	Motor Mounting Bracket
4	Release Cam
5	Drive Sprocket
6	Release Linkage
7	Manual Operator Lever
8	Roller Chain
9	Control Panel
10	Limit Switch Drive Sprocket

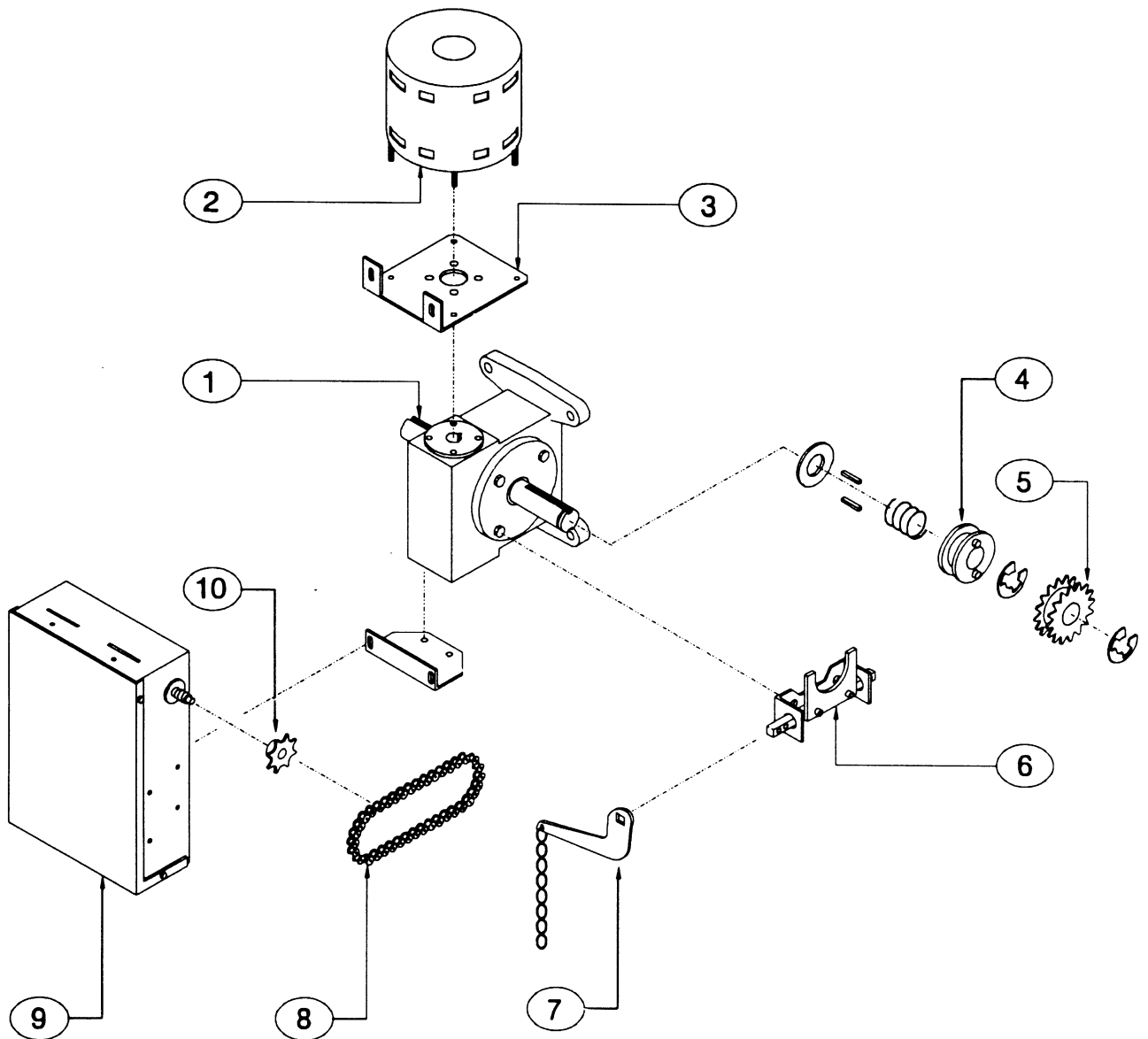

CAUTION:
ONLY TRAINED PERSONNEL SHOULD PERFORM MAINTENANCE.

**MAINTENANCE
INSTRUCTIONS FOR
SDI MODEL FD FIRE
DOORS**

1. INSPECT FOR CONFORMANCE TO NFPA 80:
 - a. Installation
 - b. Fuse Links
 - c. Mounting

2. INSPECT CONDITION OF:
 - a. Curtain
 - b. Bottom Bar
 - c. Hood
 - d. Bracket
 - e. Guide
 - f. Barrel
 - g. Operating Assembly
 - h. Governor Assembly
 - i. Fuse Links
 - j. Release Holders
 - k. Smoke Detectors
 - l. Raceways
 - m. Cabling

3. LUBRICATE:
 - a. All Pivot Joints
 - b. Shafts
 - c. Roller Chain

4. CHECK NORMAL OPERATION:
 - a. Operation
 - b. Spring Tension
 - c. Balance

5. TEST DROP

6. CAUTION: ONLY TRAINED PERSONNEL SHOULD TEST AND RESET FIRE DOORS.
 - a. Reset per Manufacturer's Instructions only.

NOTE:
For maintenance or repair of this door, please consult your local authorized Distributor.

